

Product Data Sheet

3-Series Motion Sensor

3305-G

Centralite®

Last Updated: November 2018

Product Overview

The 3-Series Motion Sensor adds both security and advanced home automation features to your connected home. You can be notified when there's movement in a certain area and even trigger lighting scenes, HVAC settings, and security alarms based on the detection of motion.

Dimensions

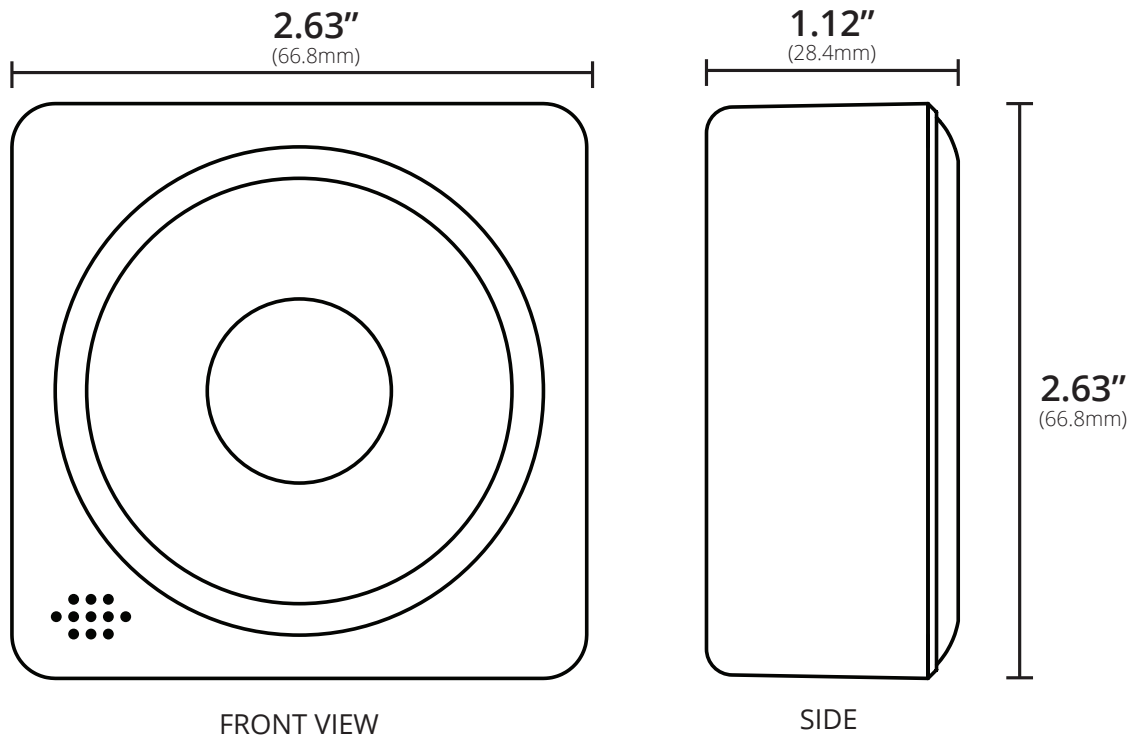

In the Box:

- 1x - 3-Series Motion Sensor
- 1x - Wall Mount Bracket
- 1x - CR-2 Battery
- 1x - Quick Start Guide

Key Features:

- Built-in power amplifier for exceptional range.
- Easy-to-install mounting plate for sensor.
- Easy compatibility with other manufacturers' ZigBee HA 1.2 devices.
- Built-In temperature sensor
- Pull-to-pair joining process.
- Over-the-air firmware updates.

Use Cases

- Save energy by turning off lights in areas that aren't being used.
- Receive alerts if motion is detected while you're away.

Save energy by turning off lights in areas that aren't being used.

Energy is wasted any time lights are on in a room that isn't being used. By adding a 3-Series Motion Sensor to the room, your home can automatically turn off lights when there hasn't been activity for more than 15 or 30 minutes.

Create custom automatic flood light and entry scenes.

Install the 3-Series Motion Sensor near the front door or garage to trigger "welcome" lighting scenes in

- Create custom automatic flood light and entry scenes.
- Use time-based motion triggers to light a path at night.

the home. Upon motion in a garage, the home can automatically turn on garage, hallway, living room, and outdoor flood lights.

Use time-based motion triggers to light a path at night.

Combine the Motion Sensor with time-based rules to automatically dim lights low at night. For a late night trip to the kitchen or bathroom, the Motion Sensor can trigger lights to fade up to only 20%, saving your eyes from bright, harsh light.

Special Features

Easy Mounting Options

The 3-Series Motion Sensor can be installed using either adhesive strips or mounting screws (both included). The easy-to-install mounting plate attaches with a single screw and the sensor simply slides into place on the mount.

Pull-to-Pair Join Process

All 3-Series sensors feature "pull-to-pair" joining. The device ships with the battery pre-installed and all that is needed to begin the joining process is to pull out a small plastic tab from the bottom of the device. There is nothing for the user to take apart or put back together.

ZigBee Home Automation 1.2 Compatibility

The 3-Series Motion Sensor is fully ZigBee HA 1.2 certified and is guaranteed to function with all open, ZigBee HA 1.2-certified hubs and devices.

Superior Range and Updatability

The 3-Series Motion Sensor includes a built-in power amplifier, giving the module superior range and stability in large homes or areas with wireless interference.

The Motion Sensor also supports over-the-air updates providing for seamless upgrades and feature additions without the need for any user interaction.

Getting Started

Step 1: Open ZigBee Network for Joining

Using your controller or hub's interface, enable the ZigBee network for joining.

Step 2: Pull Tab from Bottom of Sensor

Pull the small plastic tab out of the bottom of the sensor and it will immediately begin searching for a network to join.

Step 2: Finish Joining at Hub (optional)

Some hubs and controllers require additional steps such as naming or categorizing the device.

Troubleshooting

Step 1: Remove and Replace Battery from Device

Remove cover from sensor. Remove battery and replace with a new CR-2 battery. Reassemble and test operation.

Step 2: Factory Reset and Rejoin

Remove cover from sensor and remove battery. While holding down the reset button, reinsert battery to factory reset the device. Repeat the "Getting Started" steps to rejoin the ZigBee network.

Compatibility

The 3-Series Motion Sensor features out-of-the-box compatibility with any ZigBee HA 1.2-certified hub, controller, bridge, or platform.

Technical Specifications

Power

Rated: 3V
Battery: CR-2 (1x)
Battery Life: 2 to 3 years

Environmental

Operating Temperature: 0° to 40°C

Shipping / Storage

Temperature: -20° to 50°C
Humidity Range: 0 to 90% RH.
(non-condensing)

Approvals:



Wireless RF

Protocol: ZigBee HA 1.2
TX Strength: +18 dBm
RF Channels: 16
Range: 300+ ft. (90+ m) L.O.S.
Temp Accuracy: ± 1.8 °C (max), -10 to 85 °C
Precision: ± 0.1 °C

Support

Centralite offers both Tier-1 and Tier-2 support structures to meet the needs of different customers. For those customers that provide existing, in-house support for systems, Centralite can serve as Tier-2 support specialists. For Centralite retail-branded products, Centralite provides direct Tier-1 support for all products.

Standard Warranty

Centralite offers a standard 12-month limited warranty on the 3-Series Motion Sensor.

Additional mandatory warranty period in compliance with local law product is being sold.

Contact Sales

For more information about sales or distribution, please contact:

877-466-5483
+1 251-607-9119 (Int'l)
sales@centralite.com

Centralite Systems, Inc.
1701 Industrial Park Drive
Mobile, AL 36693

<http://centralite.com>

Notice: Any content, factual information, or specifications containing errors in this document are solely inadvertent and will be corrected upon discovery. Specifications for unreleased/planned products are subject to change.