



Always Connected. Always Covered.

# Door/Window Sensor

DMWD1



## User Manual

# Preface

As this is the full User Manual, a working knowledge of Z-Wave automation terminology and concepts will be assumed. If you are a basic user, please visit [www.domeha.com](http://www.domeha.com) for instructions. This manual will provide in-depth technical information about the Door/Window Sensor, especially in regards to its compliance to the Z-Wave standard (such as compatible Command Classes, Association Group capabilities, special features, and other information) that will help you maximize the utility of this product in your system.

# Table of Contents

Preface.....	2
Description & Features.....	4
Specifications.....	5
Physical Characteristics.....	6
Inclusion & Exclusion.....	7
Factory Reset & Misc. Functions.....	8
Physical Installation.....	9
LED Behavior.....	11
Button Behavior.....	12
Compatible Command Classes.....	13
Compatible Command Classes Cont'd.....	14
“Configuration” Command Class Parameters.....	15
Troubleshooting.....	16
Warranty & Support.....	17

# Description & Features



The Dome Door/Window Sensor is a battery powered Z-Wave Plus magnetic reed switch that can monitor the status of doors, windows, and anything else that opens and closes. The Door/Window Sensor consists of two parts - the “sensor,” and the “magnet.” The sensor has a “reed switch” inside, which is sensitive to the magnet’s presense when aligned properly and within the defined distance. When the sensor and magnet are brought together or pulled apart, the sensor will report its open/close status to its Z-Wave controller.

## Key Features:

- » Z-Wave Plus Certified
- » Up to 150' range
- » Three-Year Battery Life
- » Low Battery Indication
- » 0.5” Max distance between sensor & magnet
- » Monitor doors, windows, medicine cabinets, drawers, garage doors, and many other openings

# Specifications

## Technical Specifications

Radio protocol	Z-Wave(500 series)
Power supply	Single CR14250 (1/2AA) 3.6V battery
Standby current	2.5uA
Working current	35mA
Operating temperature	32 - 104 °F (0 - 40 °C)
Radio frequency	908.4 MHz US
Range	Up to 120' - 150' depending on environment
Dimensions (L x W x H)	Sensor: 2.75" x 0.8" x 0.8" (70 x 20 x 20 mm) Magnet: 1.3" x 0.5" x 0.5" (40 x 11 x 11 mm)

Table 1 - Technical Specifications

## Package Contents:



User Manual

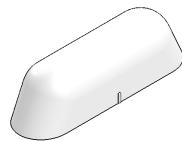

Sensor



Magnet



4x Screws



4x Wall Anchors

# Physical Characteristics

The names used in Figures 1 & 2 will be used throughout this manual. Please refer to this page as needed.

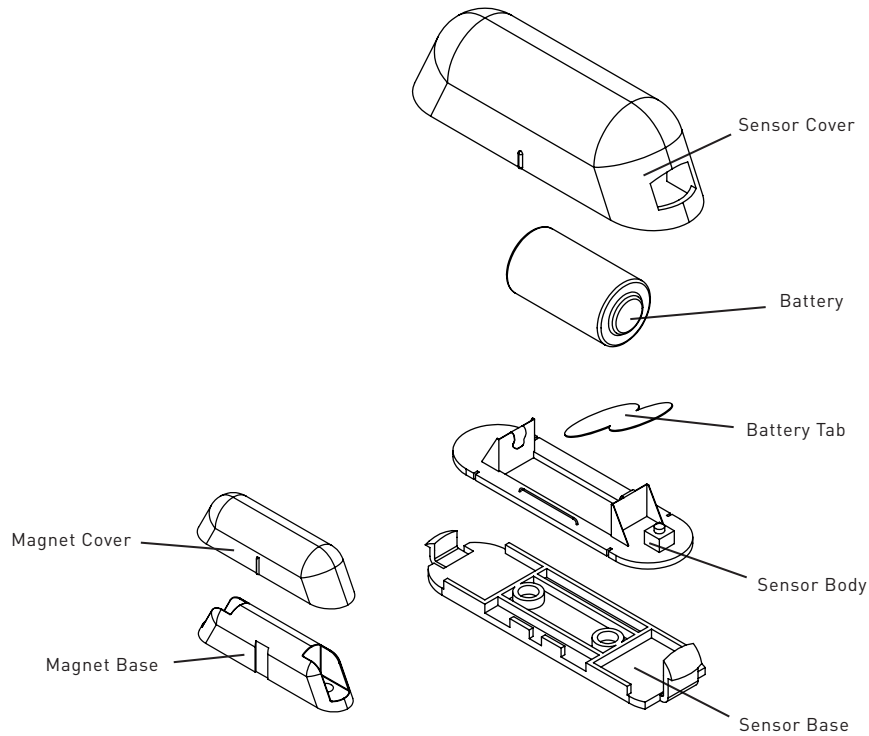

Figure 1 - Exploded View

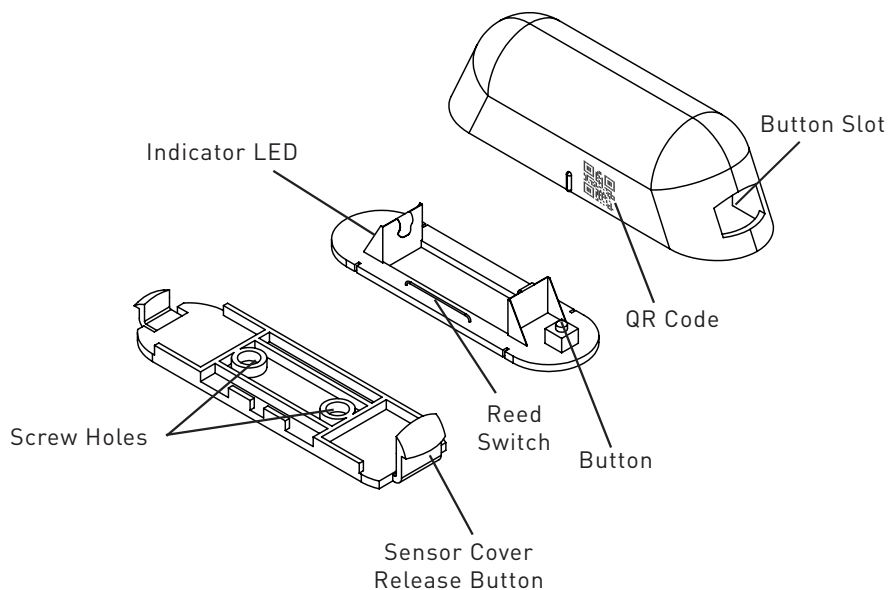

Figure 2 - Main Parts of the Door/Window Sensor

# Inclusion & Exclusion

## Inclusion

If using the Dome Hub, open the App, navigate to the side menu (≡,) and tap “Add New Device” The App will guide you through the inclusion process.

If using a 3rd party controller, follow the controller manufacturer’s instructions to enter inclusion mode.

When prompted by the controller:

1. Remove the SENSOR COVER.
2. Remove the BATTERY TAB.
3. Press the BUTTON quickly 3 times in a row.

A red LED will flash five times indicating inclusion.



Note: The Door/Window Sensor should be within 10’ of your Z-Wave controller for the inclusion process. After successful pairing, the device can be brought to the desired location.

## Exclusion

If using the Dome Hub, open the App, navigate to the side menu (≡,) tap “Device Settings,” select the device you wish to remove, and press “Delete Device.”

If using a 3rd party controller, follow the controller manufacturer’s instructions to enter exclusion mode.

When prompted by the controller:

1. Remove the SENSOR COVER from the rest of the sensor.
2. Press the Connect button quickly 3 times in a row.

A red LED will flash five times indicating exclusion/disconnection.

# Factory Reset & Misc. Functions

## Resetting the Door/Window Sensor

If needed, the Door/Window Sensor can be reset locally by following these steps. Only do this when your Z-Wave controller is disconnected or otherwise unreachable. Beware that resetting your device will disconnect it from the system:

1. Remove the SENSOR COVER and confirm that your Door/Window Sensor is powered up.
2. Press and hold the BUTTON for at least 10 seconds then release. A flashing light indicates a successful factory reset.
3. The Door/Window Sensor's memory will be erased to factory settings.

## Waking Up The Door/Window Sensor

Because the Door/Window Sensor is a battery powered device, it wakes up on regular intervals to give battery and other status updates to the controller, as well as to accept configuration settings from the controller (as opposed to always remaining online and draining its battery.) The device can be forced to wake up (to submit these reports or accept new settings immediately) by simply pressing and holding the BUTTON for two seconds.



# Physical Installation

The Door/Window Sensor can be secured with the pre-applied double stick tape or the provided hardware. The device should already be included in your Z-Wave system before continuing further.

## Pre-Installation Checklist

- ✓ The MAGNET and SENSOR should be less than 1/2" apart when closed (Figure 4.)
- ✓ Hold the magnet and sensor in place by hand where you wish to install them, move them in and out of the closed position, and make sure the INDICATOR LED blinks in response. This will confirm that the door and frame are spaced correctly to accommodate the sensor.
- ✓ Make sure the SENSOR COVER RELEASE BUTTON will be accessible in the final position.
- ✓ Finally, confirm that you are still within range of your Z-Wave controller.

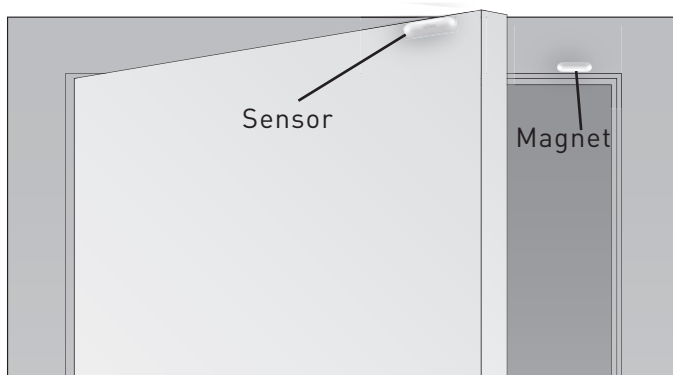

Figure 3 - Door/Window Sensor Installation Location

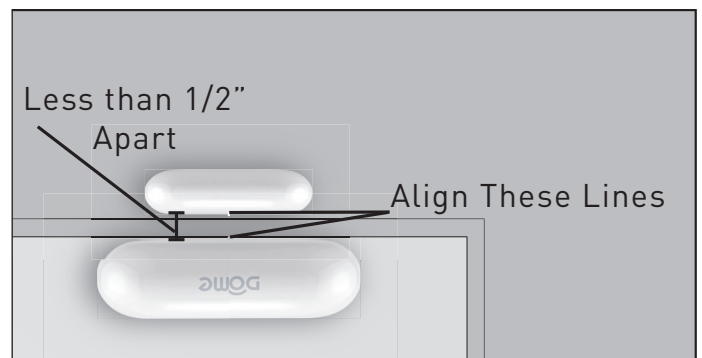

Figure 4 - Sensor Alignment

## Installation Using Double-Stick Tape

1. Wipe the door and doorframe clean of dust and anything else that will interfere with the tape's stickiness.
2. Peel the double-stick tape and adhere the SENSOR to the door surface.
3. Repeat the process for the MAGNET, making sure the MAGNET and SENSOR are no more than 1/2" apart when closed. The lines on the sides of the MAGNET and SENSOR should be in line.
4. Open and close the door to make sure the sensor works as expected (the INDICATOR LED blinks) and that the signal reaches your Z-Wave controller.

## Installation Using Screws

1. Remove the SENSOR COVER and BATTERY from the SENSOR BASE and the MAGNET COVER from the MAGNET BASE.
2. Hold the SENSOR BASE in place and drive the included screws through the screw holes into the door.
3. Repeat the process for the MAGNET, making sure the MAGNET and SENSOR are no more than 1/2" apart when the door is closed. The lines on the sides of the MAGNET and SENSOR should be in line.
4. Replace the BATTERY, SENSOR COVER, and MAGNET COVER.
5. Open and close the door to make sure the sensor works as expected (the INDICATOR LED blinks) and that the signal reaches your Z-Wave controller.

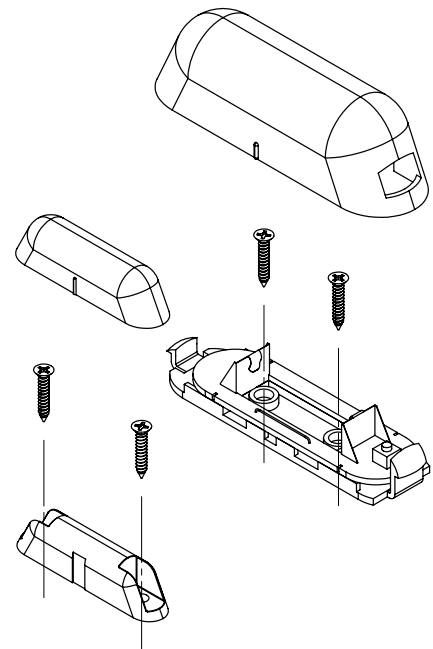

Figure 5 - Screw Alignment

# LED Behavior

Color	Behavior	This happens when...
Red	Blink 5 times in 5 seconds (slow)	...the Door/Window Sensor was just powered on, but is not yet included in a system.
	Blink 5 times in 2.5 seconds (medium)	...the BUTTON is pressed 3 times quickly (regardless of inclusion status.)
	Blink 5 times in 1.5 seconds (fast)	...the Door/Window Sensor is powered on, and already included in a system.
	Stay on for 2+ seconds straight	...the BUTTON is pressed and held for 10+ seconds, resetting Door/Window Sensor to factory settings.
	Blinks once for 1 second	...the SENSOR detects the MAGNET getting close or moving away (when the door opens or closes.)
	Blinks once	...the <b>BUTTON is pushed once.</b>

Table 2 - LED Blinking Behavior

# Button Behavior

Action	Condition	Result
Press and hold BUTTON for 2 seconds	Door/Window Sensor Already Included in System	Device sends a wake up notification to its controller, awaits further instructions, and blinks the LED Indicator once
Push BUTTON 3 Times	Door/Window Sensor Already Included in System	Device sends node info to Group 1
	Door/Window Sensor Already Included, and Controller is in Exclusion Mode	Device is excluded from the system and removes the Home ID from its memory
	Door/Window Sensor Not Yet Included in System, and Controller is in Inclusion Mode	Device enters inclusion mode and includes into whichever network is also in inclusion mode
Press and hold BUTTON for 10+ seconds	Door/Window Sensor Already Included in System	Device will be reset to factory settings, and a DEVICE_RESET_LOCALLY command will be sent to Node 1

Table 3 - Button Behavior

# Compatible Command Classes

Command Class	Notes
Z-Wave Plus Info V2 (0x5E)	-
Version V2 (0x86)	-
Manufacturer Specific V2 (0x72)	-
Device Reset Locally V1 (0x5A)	-
Powerlevel V1 (0x73)	-
Battery V1(0x80)	-
Association Group Information V1 (0x59)	
Association V2 (0x85)	<p><b>Group 1</b> Group 1 is the “Lifeline” group, which can hold five members, typically including the main Z-Wave controller. The Door/Window Sensor sends this group a Notification Report and a Binary Sensor Report when it is opened or closed. It also sends this group a Battery Report in response to Battery Get commands.</p> <p><b>Group 2</b> The Door/Window Sensor sends a Basic Set command to Association Group 2 (or the Control Group) to directly trigger devices (like a light, chime, etc.) in response to events. Then, after a preset delay, a BASIC_SET(0x00) command is sent to reset the device (e.g. turn off the light.) The value of the Basic Set command (e.g. brightness of the lamp,) and the delay time before the BASIC_SET(0x00) is sent is configured using configuration parameters 1 and 2 respectively.</p> <p><b>Group 3</b> Group 3 supports up to 5 members and the Door/Window Sensor sends it a NOTIFICATION_REPORT when the door either opens or closes.</p> <p><b>Group 4</b> Group 4 supports up to 5 members and the Door/Window Sensor sends it a SENSOR_BINARY_REPORT when the door either opens or closes.</p>

Table 4 - Command Classes

Continued on page 14...

# Compatible Command Classes Cont'd

Command Class	Notes
Wake Up V2 (0x84)	The wake-up interval is set in seconds, and is 43,200 seconds (12 hours) by default. The wake-up interval can be set to any value from 300s (5 minutes) to 16,777,200s (about 190 days) in 60-second increments.
Notification V4 (0x71)	The Door/Window Sensor sends a Notification Report when opened or closed. See below for the NOTIFICATION_REPORT parameters sent:  <b>Notification Type:</b> NOTIFICATION_TYPE_ACCESS_CONTROL <b>OPEN Event:</b> NOTIFICATION_EVENT_ACCESS_CONTROL_WINDOW_OR_DOOR_IS_OPENED <b>CLOSE Event:</b> NOTIFICATION_EVENT_ACCESS_CONTROL_WINDOW_OR_DOOR_IS_CLOSED
Binary Sensor (0x30)	The Door/Window Sensor also sends a Binary Sensor Report when opened or closed. See below for the SENSOR_BINARY_REPORT parameters sent:  <b>Sensor Type:</b> SENSOR_DOOR_WINDOW <b>OPEN Value:</b> 0xFF <b>CLOSE Value:</b> 0x00
Configuration V1(0x70)	See ""Configuration" Command Class Parameters" on page 15.

Table 5 - Command Classes Continued

# “Configuration” Command Class Parameters

The following configuration parameters are available:

Param #	Size	Name	Available Settings	Default Setting					
1	This parameter sets the delay time from when the Door/Window Sensor sends the BASIC_SET command to Association Group 2 and when the BASIC_SET(0) is sent. It accepts a value up to 65535, in seconds.								
	2 Bytes	BASIC_SET Off Delay	1 ~ 65535 (in seconds)	30 s					
2	This parameter sets the value sent by the BASIC_SET command to Association Group 2 (for more information, see “Association Groups”.)								
	1 Byte	BASIC_SET Level	<table border="1"> <tr> <td>0</td> <td>Off/Cancel Alarm/Etc.</td> </tr> <tr> <td>1~99</td> <td>Dim Level (Multilevel Switch)</td> </tr> <tr> <td>255</td> <td>On (Binary Switch)</td> </tr> </table>	0	Off/Cancel Alarm/Etc.	1~99	Dim Level (Multilevel Switch)	255	On (Binary Switch)
0	Off/Cancel Alarm/Etc.								
1~99	Dim Level (Multilevel Switch)								
255	On (Binary Switch)								

Table 6 - Door/Window Sensor Configuration Parameters

# Troubleshooting

**Q: Help! My Door/Window Sensor paired successfully, but my controller can't see it anymore after I installed it!**

A: First, make sure your battery didn't come loose during set-up. Otherwise, the Z-Wave signal is probably weak in that area of your home. Remember that the 120' - 150' range doesn't take into account walls, furniture, and other obstacles. To boost your Z-Wave network coverage, add a few non-battery powered Z-Wave devices between the controller and the furthest device, like the Dome On/Off Plug or Water Main Shut-Off. You can even purchase dedicated Z-Wave extenders from 3rd party manufacturers.

**Q: There's so many words in this manual I don't understand. How can I learn more about Z-Wave?**

A: Remember you don't have to understand everything in this manual to start automating your home. Our Quick-Start Guides have all you need to start using any device. For more thorough information about Z-Wave home automation, visit [www.domeha.com/support](http://www.domeha.com/support).

**Q: My sensor keeps telling me it's open when my door is closed!**

A: Your magnet and sensor are probably too far apart. Try remounting one of them closer to the other, and it should start working consistently.

**Q: I've tried multiple times, but I can't include the Door/Window Sensor in my system.**

A: Check your battery and make sure your device is getting power. Then, follow the instructions under "Factory Reset & Misc. Functions" on page 8 and try going through the inclusion process again. If you are still having issues, please visit [www.domeha.com/support](http://www.domeha.com/support)

**Q: All of a sudden, my Door/Window Sensor is offline.**

A: Check your battery and make sure your device is getting power. If powered, make sure you still have Z-Wave network coverage. If you are still having issues, visit [www.domeha.com/support](http://www.domeha.com/support).



# Warranty & Support

If you have questions, our trained Customer Service Department is happy to assist you 24 hours a day, 7 days a week. Contact Dome Customer Service as follows: • In North America dial: 1-855-249-1754 • Email Dome at support@domeHA.com

**DO NOT RETURN THIS PRODUCT TO THE STORE OR WEBSITE FROM WHICH IT WAS PURCHASED**

If you believe the product is defective, has a missing or broken part or are having difficulty with it please contact Dome as listed above for a quick and efficient solution to the problem.

**Legal Notices:** This device complies with part 15 of the FCC rules. Operation is subject to the following two conditions (1) This device may not cause harmful interference, and (2) this device must accept any interference received, including interference that may cause undesired operation.

**Note:** This equipment has been tested and found to comply with the limits for a Class B digital device, pursuant to part 15 of the FCC Rules. These limits are designed to provide reasonable protection against harmful interference in a residential installation. This equipment generates, uses and can radiate radio frequency energy and, if not installed and used in accordance with the instructions, may cause harmful interference to radio communications.

However, there is no guarantee that interference will not occur in a particular installation. If this equipment does cause harmful interference to radio or television reception, which can be determined by turning the equipment off and on, the user is encouraged to try to correct the interference by one or more of the following measures: Reorient or relocate the receiving antenna; increase the separation between the equipment and the receiver; connect the equipment into an outlet on a circuit different from that to which the receiver is connected. Consult the dealer or an experienced radio/TV technician for help.

This device complies with Industry Canada license-exempt RSS standard(s). Operation is subject to the following two conditions: (1) this device may not cause interference, and (2) this device must accept any interference, including interference that may cause undesired operation of the device.

Elexa Consumer Products, Inc. ("ECP") warrants to the original retail purchaser ("Purchaser") that the DOME Window/Door sensor (the "Product") will be free of defects in materials or workmanship under use for one (1) year from the date of purchase [the "Warranty period"].

For the Purchaser only, if the Product fails to perform as specified during the Warranty Period due to defective parts or faulty workmanship, ECP will repair or replace the defective or damaged parts of the Product. Normal wear and tear is not covered nor is abnormal use, misuse, mishandling, faulty installation, improper shipping, damage caused by disasters such as fire, flood or earthquake, neglect, accident or tampering. This warranty covers only normal use in the United States or Canada.

To obtain warranty service during the Warranty Period, call Dome Customer Service (1-855-249-1754) or email: support@domeHA.com for instructions on sending damaged parts and documentation for a Return Material Authorization (RMA). Products returned to ECP for repair or replace-

ment without authorization will be returned at the sender's expense. All warranty claims must be accompanied by a legible copy of the original receipt showing date and details of purchase. The RMA number must be clearly written on the side of the shipping container in which you return the Product or defective parts. Unless otherwise instructed by ECP, the Product must be sent freight pre-paid to the following address:

Elexa Consumer Products, c/o Promac,  
1153 Timber Dr., Elgin, IL 60123

ECP will repair or replace the defective parts and return them at ECP's cost by a shipping method selected by ECP. When contacting ECP to obtain an RMA, Purchaser may request expedited return shipping at Purchaser's expense.

**THIS WARRANTY IS NOT TRANSFERABLE, AND, TO THE MAXIMUM EXTENT PERMITTED BY APPLICABLE LAW IS IN LIEU OF ALL OTHER WARRANTIES, REPRESENTATIONS AND CONDITIONS, EXPRESSED OR IMPLIED, STATUTORY OR OTHERWISE, INCLUDING BUT NOT LIMITED TO THE IMPLIED WARRANTIES OF MERCHANTABILITY AND FITNESS FOR A PARTICULAR PURPOSE. NO OTHER PERSON OR REPRESENTATIVE IS AUTHORIZED TO MAKE ANY OTHER WARRANTY ON BEHALF OF ECP OR ASSUME FOR ECP ANY OTHER LIABILITY IN CONNECTION WITH THE SALE OF THIS PRODUCT. IN NO EVENT WILL ECP BE LIABLE FOR ANY DAMAGES, INCLUDING BUT NOT LIMITED TO INCIDENTAL, SPECIAL OR CONSEQUENTIAL DAMAGES ARISING OUT OF THE USE OR INABILITY TO USE THE PRODUCT, INCLUDING DAMAGES DUE TO ECP'S NEGLIGENCE.**

**THIS WARRANTY GIVES YOU SPECIFIC LEGAL RIGHTS, AND YOU MAY ALSO HAVE OTHER RIGHTS WHICH VARY FROM STATE TO STATE AND COUNTRY TO COUNTRY.**

This marking on the product, accessories or literature indicates that the product and its electronic accessories should not be disposed of with other household waste.

To prevent possible harm to the environment or human health from uncontrolled waste disposal, please separate these items from other types of waste and recycle them responsibly to promote the sustainable reuse of material resources.

Household users should contact either the retailer where they purchased this product, or their government office, for details of where and how they can take these items for environmentally safe recycling.

Business users should contact their supplier and check the terms and conditions of the purchase contract. This product and its electronic accessories should not be mixed with other wastes for disposal.

This marking on the battery, manual or packaging indicates that the batteries in this product should not be disposed of with other household waste. Where marked, the chemical symbols Hg, Cd or Pb indicate that the battery contains mercury, cadmium or lead above the reference levels in EC Directive 2006/66. If batteries are not properly disposed of, these substances can cause harm to human health or the environment.