

Instruction Manual

Door Sensor

Thank you for your support

- Please read the instruction manual carefully before operating
- Please keep the instruction manual **for further reference**



Shenzhen NEO Electronics Co., LTD

Product Introduction

Door sensor is an intelligent security equipment that can transmit the Z-Wave network which has particular frequency. In the Z-Wave network communications, door sensor can be connected to any Z-wave main controller. The door sensor can send messages to the Z-wave main controller, and realize association with other devices through the Z-wave main controller. Different countries or areas, the radio frequency is different. In the communication with the Z-wave main controller, the door sensor can send messages to the Z-wave main controller, but it can not receive messages from the Z-wave main controller. When alarm is triggered, the door sensor sends messages to the Z-wave main controller, the Z-wave main controller will displays the current status of door sensor, so the door sensor can associate with other devices. Door sensor is battery powered, is small and can be installed on the window or door easily. When the door or window is open, the door sensor is triggered and linkage alarm realized.

Technical parameters

- Power: CR14250 x1
- Standby current: 1uA
- Battery life: 1 years
- Radio Protocol: Z-wave
- Radio Frequency: 868.4MHz EU; 908.4MHz US; 921.4MHz ANZ; 869.2MHz RU
- **Compatible with 300 series and 500 series**
- Wireless distance: 50m
- Operation temperature: 0-40°C
- Storage temperature: 0-60°C
- Size: Contact sensor main body (L x W x H): 70mmx20mmx20mm
Contact sensor deputy body (L x W x H): 40mmx11mmx11mm

Technical Information

- Install on the door or window.
- Battery powered.
- Easily install with screws or sticker.
- Associate with other devices through the gateway.
- Compatible with any Z-Wave network.

Product Configuration

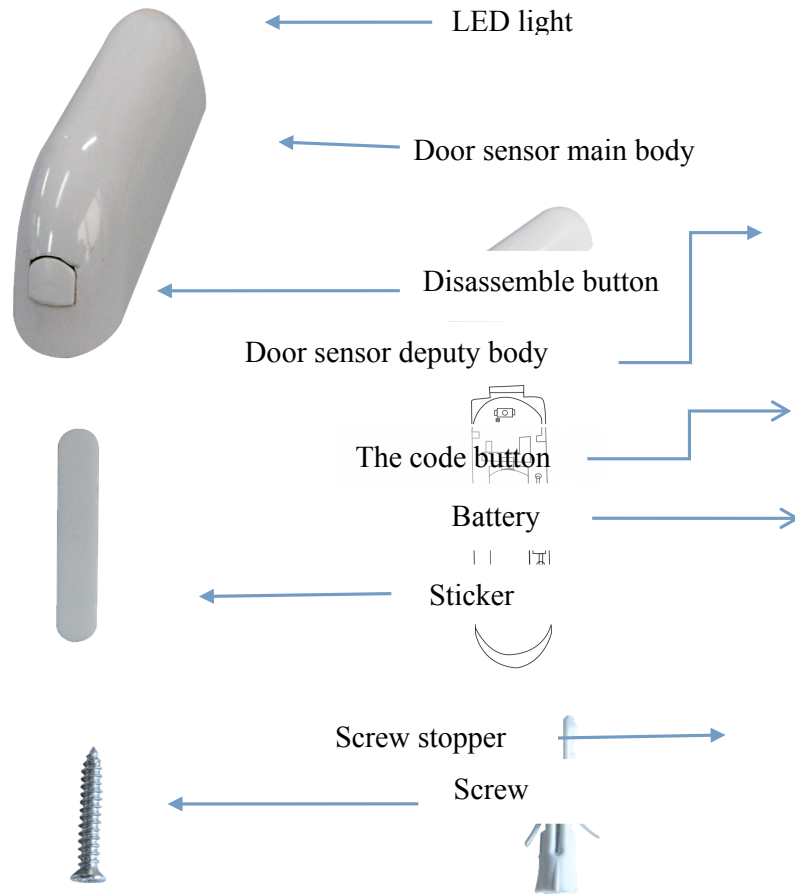

Product List

- Door sensor main body 1pc
- Door sensor deputy body 1pc
- Battery 2pcs
- Screw 6pcs
- Screw stopper 6pcs
- Sticker 2pcs
- Instruction manual 1pc

Including Sensor (Door sensor) to Z-Wave Network

The door sensor can be included to the Z-wave network by pressing the code button.

- 1) Disassemble the door sensor main body and insert the battery. Make sure the device is located within the direct range of the controller.
- 2) Set the controller into the learning mode (see main controller's operating manual).
- 3) Quickly, triple click the code button, LED light will flash for 5 times.
- 4) Door sensor will be detected and included in the Z-Wave network.
- 5) Wait for the main controller to configure the sensor.

Excluding Sensor (door sensor) from Z-Wave Network

- 1) Make sure the sensor is connected to power source.
- 2) Set the main controller into the learning mode (see main controller's operating manual).
- 3) Quickly, triple click the code button, LED light will flash for 5 times.
- 4) Wait for the main controller to delete the sensor.

Installation Steps

- Door sensor Installation
- Battery Installation

Door sensor Installation

- **Option One**

Disassemble the door sensor main body and take out battery, fix it on the door with screws.

Disassemble the door sensor deputy body and fix it on the corresponding door frame position

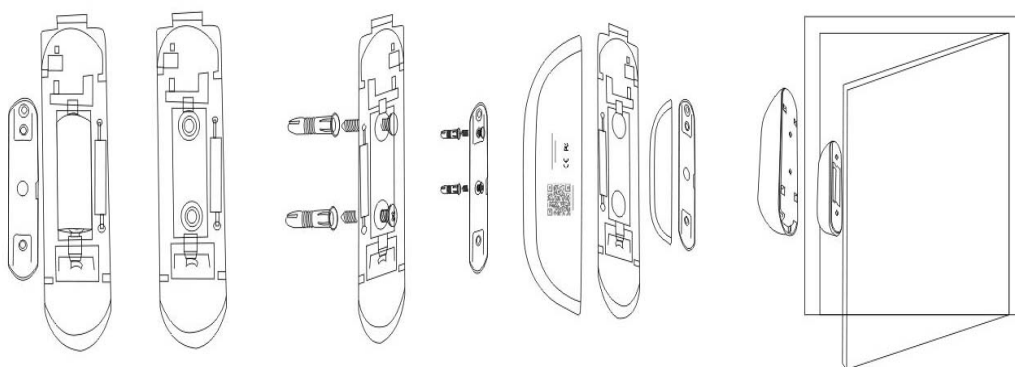

- **Option Two**

Put the sticker on the bottom of door sensor to fix it on the wall

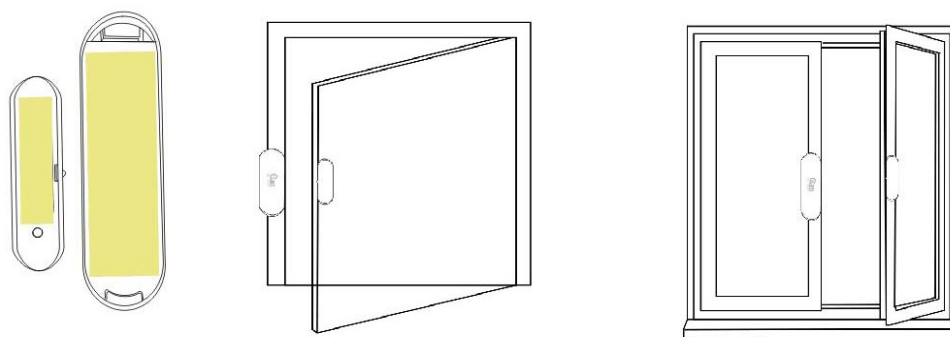

NOTE

When installing the door sensor, door sensor deputy body must be installed on the bulge side of the door sensor main body.

Battery Installation

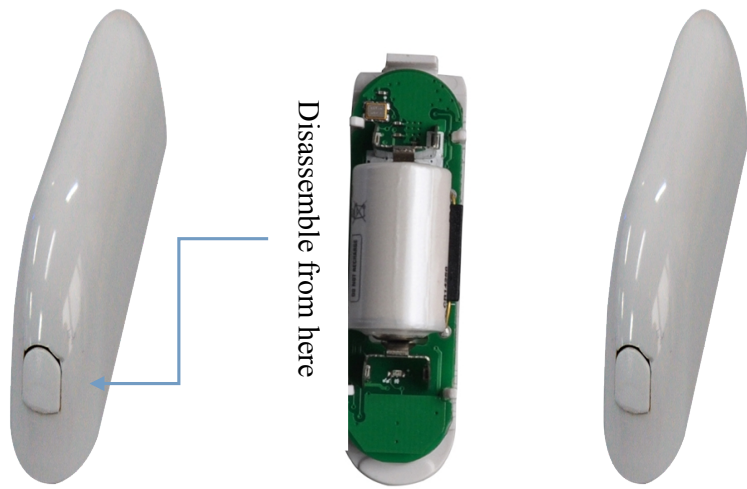

Disassemble the door sensor
main body

Install battery

Assemble the door
sensor main body

Tips

- When the door is closed, and the distance between the main body and the deputy is less than 2cm, the alarm gateway displays the door is closed perfectly.
- When the door is opened, the distance between the main body and the deputy body is more than 2cm, LED light flash and door sensor sends messages to the alarm gateway, the alarm gateway displays the door is open and alarms.
- Valid distance of door sensor is 2cm, so when install, please pay attention to the trigger surface, it is triggered by point to point.
- Make sure of that door sensor is in the alarm gateway's network.

The status of LED

1. When the door sensor is triggered, LED light flashes red for 1 times.
2. When the door sensor installs battery, LED light will flash red for 5 times.
3. Quickly, triple click the code button ,add the door sensor to the Z-WAVE network or delete door sensor from Z-WAVE network , LED light flashes red for 5 times.
4. Press on the code button for 10 seconds, the door sensor will be restored to factory default settings, LED light flashes red for 1 time.
5. In the normal condition, the LED light keeps being out.

Associations

This has the effect that when the sensor is triggered, all devices associated with the sensor will receive the relevant reports. Through an association the sensor may control another Z-Wave network devices, e.g. the alarm device, wall plug, lamp etc.

The Door Sensor supports two linkage groups:

Linkage group 1 is assigned to the device status - sending the BASIC SET control frame to the associated devices having detected motion.

Linkage group 2 reports relay's status to just one device, Z-Wave network's main controller by default. It's not recommended to modify settings of this association

NOTE

Door Sensor linkage with other devices through Z-wave network directly, alarm gateway or Z-wave controller does not take part in such communication.

Restore the Sensor (door sensor) to Factory Default Settings

Reset will delete all information on the Z-Wave network or Z-Wave controller, and restore the sensor to factory default settings.

1. Remove the cover of door sensor main body.
2. Make sure the sensor is connected to power source.
3. Press and hold the reset button for 10 seconds, LED light will flash red for 1 time.
4. Release the button.

NOTE

When the Door Sensor is being restored to factory default settings, please make sure power source is connected.

Battery Usage Tips

Battery life of the door sensor is approximately 10 years at factory default settings. The current battery level is displayed in the gateway. Red battery icon means the battery needs replaced. In order to avoid tamper detection, while replacing the battery, please disconnect the association of the door sensor with other devices.

Note

Door sensor is battery powered. Using batteries other than specified may result in explosion. Dispose of properly, please observe environmental protection rules.

Advanced Configuration

1. Configuring the OFF Delay

This configuration parameter that can be used to adjust the amount of delay before the OFF command is transmitted. This parameter can be configured with the value of 0 through 65535, where 0 means send OFF command immediately and 65535 means 65535 seconds of delay.

Function: On/Off Duration.

Parameter Number: 1.

Parameter Size: 2 Byte

Available Settings: 0-65535 (in seconds, each 1s).

Default Setting: 30 (s)

2. Basic Set Level

Basic Set Command will be sent where contains a value when the door/window is opened or closed, the receiver will take it for consideration; for instance, if a lamp module received the Basic Set Command of which value is decisive as to how bright

of dim level of lamp module shall be.

Function: Basic Set

Parameter Number: 2

Parameter Size: 1 Byte

Available Settings: 0, 1 - 99 or 255

0 – OFF, Alarm cancelling or turning a device off

1 - 99 or 255 – ON (Binary Switch Device)

Dim Level (Multilevel Switch Device)

Default Setting: 99

Command Classes

This Sensor(Door/Windows Detector) supports Command Classes as Below:

- * COMMAND_CLASS_ZWAVEPLUS_INFO (V2)
- * COMMAND_CLASS_VERSION (V2)
- * COMMAND_CLASS_MANUFACTURER_SPECIFIC (V2)
- * COMMAND_CLASS_DEVICE_RESET_LOCALLY (V1)
- * COMMAND_CLASS_POWERLEVEL (V1)
- * COMMAND_CLASS_BATTERY (V1)
- * COMMAND_CLASS_ASSOCIATION (V2)
- * COMMAND_CLASS_ASSOCIATION_GRP_INFO (V1)
- * COMMAND_CLASS_WAKE_UP (V2)
- * COMMAND_CLASS_NOTIFICATION (V4)
- * COMMAND_CLASS_SENSOR_BINARY (V2)
- * COMMAND_CLASS_CONFIGURATION (V1)

Guarantee

1. The Guarantee is provided by Shenzhen NEO Electronics Co., Ltd (hereinafter “Manufacture”).
2. The Manufacturer is responsible for equipment malfunction resulting from physical defects (manufacturing or material) of the device for 12 months from the date of its purchasing.
3. During the Guarantee period, the Manufacturer shall remove any defects, free of charge, by repairing or replacing.
4. In special cases, when the device cannot be replaced with the device of the same type (e.g. the device is no longer available in the commercial offer), the Manufacturer may replace it with a different device having technical parameters similar to the faulty one. Such activity shall be considered as fulfilling the obligations of the Manufacturer. The Manufacturer shall not refund money paid for the device.
5. The guarantee shall not cover:
 - mechanical damages (cracks, fractures, cuts, abrasions, physical deformations caused by impact, falling or dropping the device or other object, improper use or not observing the operating manual);
 - damages resulting from external causes, e.g.: flood, storm, fire, lightning, natural disasters, earthquakes, war, civil disturbance, force majeure, unforeseen accidents, theft, water damage, liquid leakage ,battery spill, weather conditions, sunlight, sand, moisture, high or low temperature, air pollution
 - damages caused by malfunctioning software, attack of a computer virus, or by failure to update the software as recommended by the Manufacturer;

Shenzhen NEO Electronics Co., LTD

Address: 6TH Floor, Building No.2, Laobing Industrial Park, Tiezhai Road Xixiang, BaoAn District, Shenzhen, China.

Http://www.szneo.com

Tel: +86-4007-888-929

Fax: +86-755-29667746

E-mail: support@szneo.com